

## General Description

Optical receiver based on a photoASIC device made by a CMOS microelectronic silicon photodiode, with integrated electronics for standard Open Collector output.

The photoASIC has been developed for industrial environment with high resolution CMOS technology, in order to work in fieldbus at standard 16 Mbps.

The optimization of antireflective coating permits to have very good optical sensitivity with low power of the incoming light.

The main advantage of this digital optical receiver, in comparison to the standard ones, is the robustness against mechanical stresses, electrostatic discharges and electromagnetic environment.

The main technical specifications, like optical sensitivity, voltage and current supply, operating frequency and optical dynamic range, are well improved for this class of optical receivers for industrial environment.

The device is protected with two packages: a standard TO18 full metal, plus an ST metal connector.

## Applications

- Optical Fiber Datacom
- Industrial LAN and FIELD BUS
- Optical Barriers
- Optical Receivers, Light Sensors
- Home and Building Automation
- Opto isolation / Opto coupler
- General Applications for Light Detection

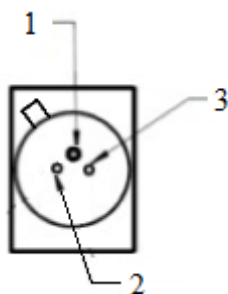

Mark=pin #1

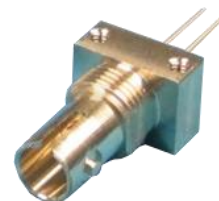

## Features

- Very High Optical Sensitivity
- Wide Dynamic Range
- Data Rate up to 16Mbps
- Working also in DC mode and low frequency
- High robustness (double metal package)
- Open collector output
- 100% manufactured in Europe

## Pin Functions

No.	Name	Function
1	VCC	5V Power Supply (marked)
2	GND	Ground
3	OUT	Open Collector Output

## Ordering information

OIA4160-ST

Optical Receiver Based on CMOS PhotoASIC  
with open collector Output in ST Metal Case

## ABSOLUTE MAXIMUM RATINGS

Symbol	Parameter	Min	Max	Unit
$T_A$	Operating Temperature Range	-40	85	°C
$T_S$	Storage Temperature	-40	85	°C
$T_{Sol}$	Lead Temperature (solder) 10s		260	°C
$V_C$	Supply Voltage	4.5	5.5	V
$V_O$	Output Voltage	-0.5	20	V
$P_D$	Power Dissipation @ $T_A=25^\circ\text{C}$		250	mW
MSL	Moisture Sensitive level		1	

Stresses beyond those listed under "Absolute Maximum Ratings" may cause permanent damage to the device. These are stress ratings only, and functional operation of the device at these or any other conditions beyond those indicated in the operational sections of the specifications is not implied. Exposure to absolute maximum rated conditions for extended periods may affect device reliability.

## ELECTRICAL CHARACTERISTICS

$T_A=25^\circ\text{C}$ , unless otherwise noted.

Symbol	Parameter	Conditions	Min	Typ	Max	Unit
$I_{ON}$	Supply Current			35	45	mA
S	Minimum Optical Sensitivity <sup>(1)</sup>	Peak		-28	-25	dBm
$\lambda_{50}$	Spectral sensitivity range	At 50%	500		975	nm
$P_{RmaxL}$	Max. received power/optical level LOW	Dc mode			-31	dBm
$P_{RmaxH}$	Max. received power/optical level HIGH	Dc mode			-5	dBm
$I_{OH}$	High level Output Current	$V_O=18\text{V}$ , $P_o < -40\text{dBm}$ $R_I=560\ \Omega$			10	uA
$V_{OL}$	Output voltage low				0.5	V

(1) Peak sensitivity, measured with 2.5MHz signal, 200um HCS 1m fiber,  $\lambda=850\text{nm}$ , duty cycle=50% PWD<50%

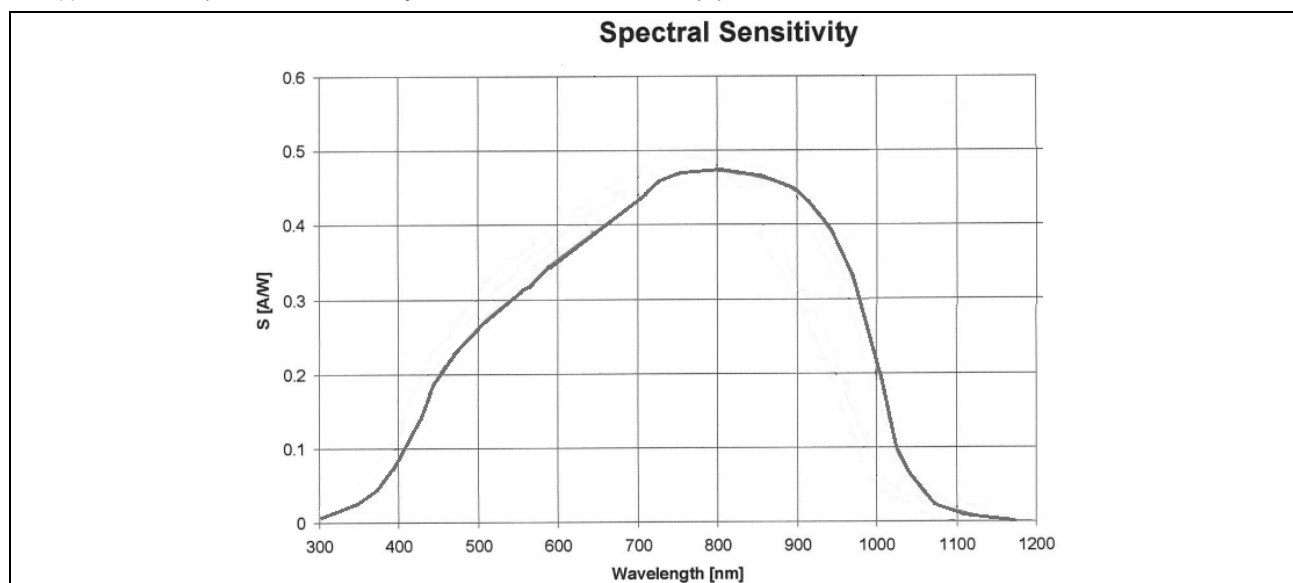

## AC SWITCHING CHARACTERISTICS

$T_A=25^\circ\text{C}$ ,  $f=2.5\text{MHz}$ ,  $V_O = 0.5$  to  $2.4\text{V}$ ,  $R_I=560\ \Omega$  unless otherwise noted.

Symbol	Parameter	Conditions	Min	Typ	Max	Unit
$t_R$	Rise Time (from 10% to 90%)	$C_l=3.9\text{pF}$ $P_{in}=-10\text{uW}$		6	9	ns
$t_F$	Fall Time (from 90% to 10%)	$C_l=3.9\text{pF}$ $P_{in}=-10\text{uW}$		7	10	ns
F	Operating Frequency <sup>(2)</sup>		0		16	Mbps
PWD	Pulse Width Distortion <sup>(3)</sup>	$6.3\text{uW} < P_{in\ pk} < 300\text{uW}$	-25		+25	%
$t_{PD}$	Propagation delay ( $P_{DLH}$ $P_{DHL}$ )	with OIL4060-ST led at 10mA, 870nm, HCS 200um		70	150	ns

(2) 16 Mbps = 8 MHz

(3) Pulse width distortion is the difference between high and low state:  $PWD = PW_{high} - PW_{low}$

RECOMMENDED CIRCUIT AND WAVEFORM DEFINITIONS

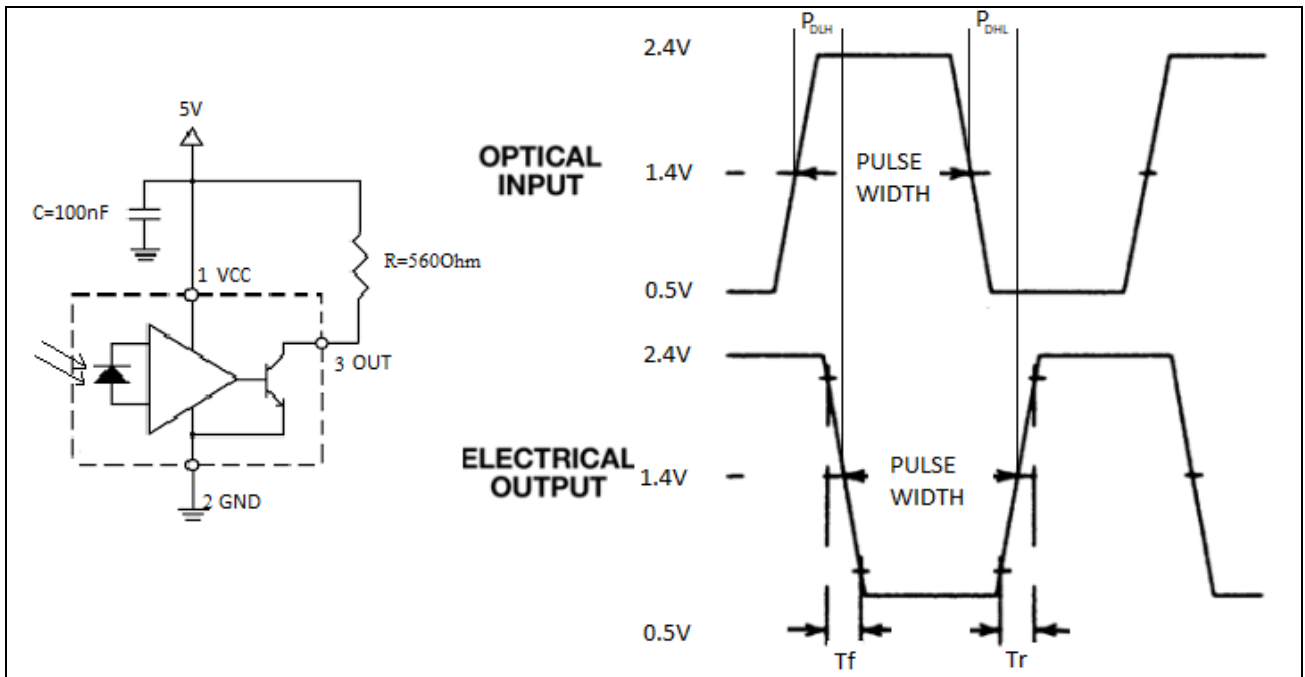

MECHANICAL DIMENSIONS

Units=mm

