

General Description

OIAC8 is a +/-2g dual-axes accelerometer. The two voltage outputs span from 0.25 to 9.75 Volt. Each axis has an additional double switch output with a trip point of +/-0.25g to signal alarm conditions.

The compact sturdy anodized metal enclosure can withstand shocks and vibrations, while the filling resin makes OIAC8 accelerometers waterproof and dustproof.

The electronics components are selected for minimizing the thermal drift of the output signal (voltage offset drift) and good sensitivity to very light accelerations. To obtain these characteristics, the MEMS's transducer raw signals are internally filtered and conditioned.

The internal protection circuits make these accelerometers electrically robust to withstand overvoltage and outputs lines overload.



Images are for illustration purpose only and may not represent exactly the product in all the details

Applications

Wind turbine monitoring
Structures monitoring
Machine vibration monitor
Shock monitoring
Industry 4.0

Pin Functions

| Cable color | Name | Function |
|-------------|-----------------|------------------------|
| Red | V _{CC} | Positive Power Supply |
| Black | P.GND | Power Ground |
| White | P.S.#1X | Pos SWITCH Contact #1X |
| Blue | N.S.#1X | Neg SWITCH Contact #1X |
| Pink | P.S.#2X | Pos SWITCH Contact #2X |
| Green | N.S.#2X | Neg SWITCH Contact #2X |
| Brown-green | P.S.#1Y | Pos SWITCH Contact #1Y |
| White-green | N.S.#1Y | Neg SWITCH Contact #1Y |
| Red-blue | P.S.#2Y | Pos SWITCH Contact #2Y |
| Grey-pink | N.S.#2Y | Neg SWITCH Contact #2Y |
| Yellow | A.Out X | Analog OUTPUT X-axis |
| Purple | A.Out Y | Analog OUTPUT Y-axis |
| Brown | A.GND X | Analog Ground for X |
| Grey | A.GND Y | Analog Ground for Y |
| Shield | C.GND | Cable Shield |

Features

- Dual axes
- Internal 6th order hardware filter, 5Hz flatness
- Wide analog outputs span 0.25 - 9.75V
- Double alarm switch on each axis
- Rugged device: fully metal case filled with protective resin
- Resistant to electrical disturbs and transients
- Power supply inversion internal protection
- Operating temperature -40°C to +85°C
- IP67 protection grade

Ordering information

OIAC8

2-axis 2g accelerometer with 0-10V
and double switches outputs

ABSOLUTE MAXIMUM RATINGS

| Symbol | Parameter | Min | Max | Unit |
|-----------------|-----------------------------------|-----|-----|------|
| T _S | Storage Temperature | -40 | 85 | °C |
| T _A | Operating Temperature Range | -40 | 85 | °C |
| V _{CC} | Supply Voltage Range (DC voltage) | 18 | 32 | V |

Stresses beyond those listed under "Absolute Maximum Ratings" may cause permanent damage to the device. These are stress ratings only, and functional operation of the device at these or any other conditions beyond those indicated in the operational sections of the specifications is not implied. Exposure to absolute maximum rated conditions for extended periods may affect device reliability.

ELECTRICAL CHARACTERISTICS

T_A = 25°C unless otherwise noted.

| Symbol | Parameter | Conditions | Min | Typ | Max | Unit |
|--------------------|-------------------------------|---|-----------------------------|-------|------|-----------------|
| I _{CC} | Current consumption | average value V _{CC} = 24V, all relays ON | | 30 | 50 | mA |
| R | Range | | | ±2 | | g |
| V _O | Output voltage | | 0.25 | | 9.75 | V _{DC} |
| Z _B | Zero BIAS (0g offset) | acceleration = 0g | 4.98 | 5.00 | 5.02 | V _{DC} |
| Z _B (T) | Zero BIAS temperature coeff. | acceleration = 0g ; 0°C < T _A < +85°C | | 0.008 | | %F.R./°C |
| F _T | Frequency response | | 5Hz Bessel filter -36dB/OCT | | | |
| A _C | Accuracy | | | ±0.15 | | % |
| R _L | Voltage outputs load resistor | | 33 | 100 | | kΩ |

SWITCH FUNCTIONS

| Parameter | Conditions |
|--------------------------|--|
| SWITCH OUTPUT FUNCTION | NORMALLY CLOSED DOUBLE POLE SINGLE THROW SWITCH CONTACTS SHALL OPEN AT TRIP POINT |
| TRIP POINT | ±0.25G |
| SWITCH OUTPUT HYSTERESIS | 10% (typically) |
| SWITCH CONTACT RATINGS | 0-60 VDC 0.5 Amp 0.15 ohm (ON-RESISTANCE TYP) 100m ohm (OFF-RESISTANCE) |

RELIABILITY PARAMETERS

All MTTF calculations are made according to Siemens SN 29500.

| Symbol | Parameter | Conditions | Value | Unit |
|--------|----------------------|--|---------------|-------|
| MTTF | Mean time to failure | Environment GM; T _A = 40°C; V _{CC} = 24V | 56 | years |
| DC | Diagnostic coverage | | None | - |
| S | Structure | | Not redundant | - |

MECHANICAL CHARACTERISTICS AND DIMENSIONS

| Symbol | Parameter | Conditions | Min | Typ | Max | Unit |
|----------------|-------------------------|------------|------------------------|------|-----|------|
| W | Width | | | 50.6 | | mm |
| L | Length | | | 77.0 | | mm |
| H | Height | | | 31.0 | | mm |
| Wt | Weight | | | 200 | | g |
| C _L | Cable standard length | | | 2 | | m |
| C _Ø | Cable outer diameter | | | 6.6 | | mm |
| C _S | Cable connection styles | | 14 conductors + shield | | | |

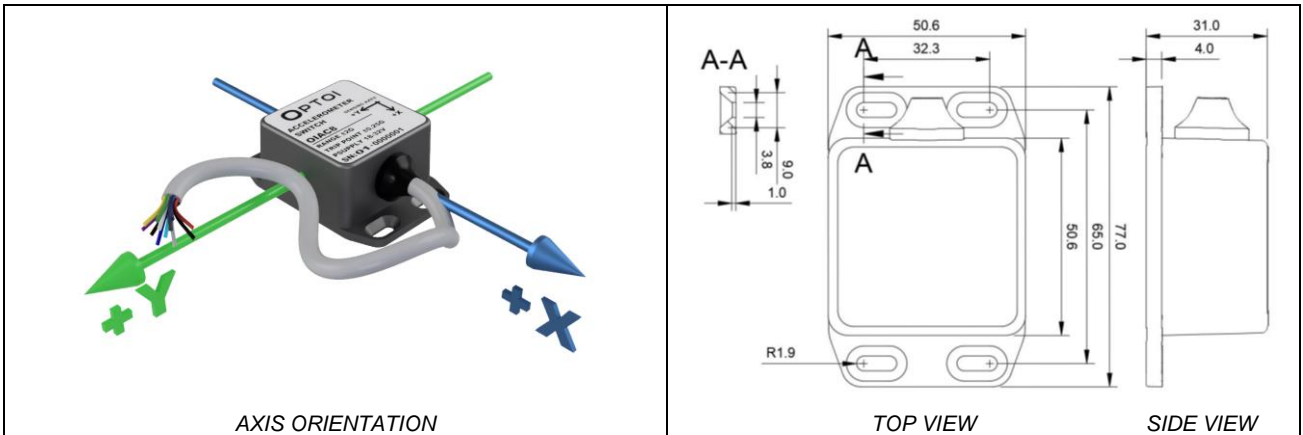

Mounting

Mount the OIAC8 accelerometer using 4 flat head countersunk screws with a maximum thread diameter of 4mm, externally centered in the 4 slot-holes.

Electrical Connections

CONNECTIONS

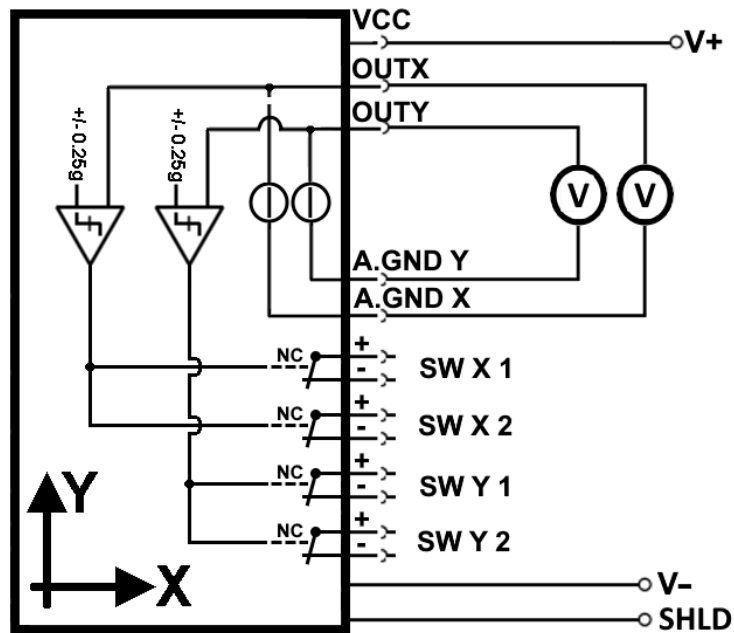

The diagram above is for illustration purpose only.
Internal drawings of the device are schematized as logic functions and may not represent the physical implementation